

(No Model.)

C. WAGNER.

REVERSING GEAR FOR SCREW CUTTING OR OTHER MACHINES.

No. 577,334.

Patented Feb. 16, 1897.

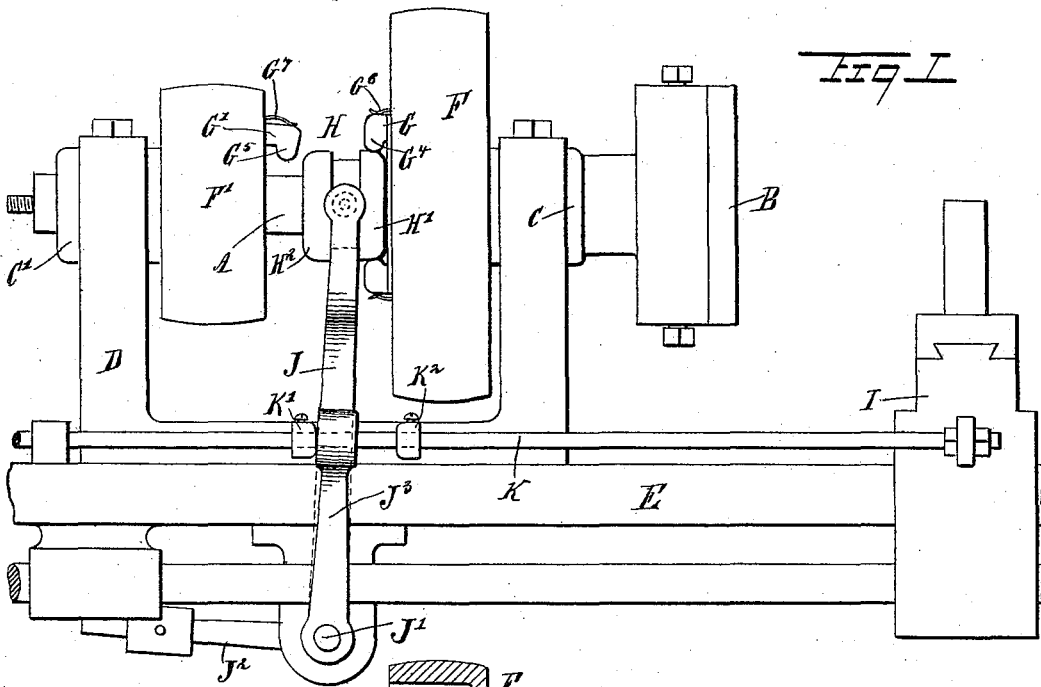

Fig 1

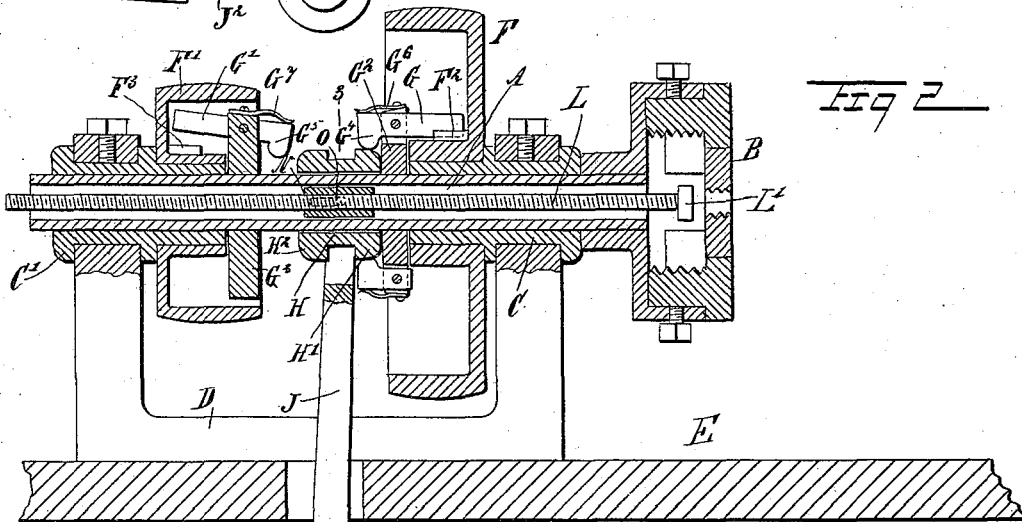

Fig 2

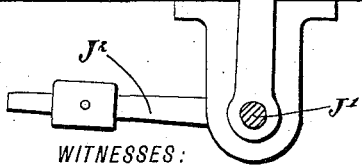
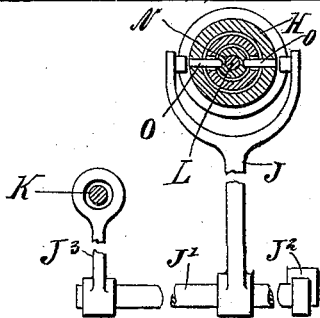

Fig 3

WITNESSES:

*W. Walker*  
*Geo. G. Foster*



INVENTOR  
*C. Wagner*

BY  
*[Signature]*  
ATTORNEYS.

# UNITED STATES PATENT OFFICE.

CHARLES WAGNER, OF NEW YORK, N. Y.

## REVERSING - GEAR FOR SCREW-CUTTING OR OTHER MACHINES.

SPECIFICATION forming part of Letters Patent No. 577,334, dated February 16, 1897.

Application filed April 25, 1896. Serial No. 589,064. (No model.)

*To all whom it may concern:*

Be it known that I, CHARLES WAGNER, of New York city, in the county and State of New York, have invented a new and Improved Reversing-Gear for Screw-Cutting or other Machines, of which the following is a full, clear, and exact description.

The object of the invention is to provide a new and improved reversing-gear for use on screw-cutting and other machines which is simple and durable in construction and arranged to conveniently set the device for reversing automatically when the desired length of thread has been cut.

The invention consists principally of a clutch-sleeve held to slide and controlled by the work or the carriage supporting the work and two clutches carried by the spindle and controlled by the sleeve, the clutches being adapted to engage driving-pulleys rotating in opposite directions.

The invention also consists of certain parts and details and combinations of the same, as will be fully described hereinafter and then pointed out in the claims.

Reference is to be had to the accompanying drawings, forming a part of this specification, in which similar characters of reference indicate corresponding parts in all the figures.

Figure 1 is a side elevation of the improvement as applied on a screw-cutting lathe. Fig. 2 is a longitudinal central section of the same, and Fig. 3 is a cross-section of the same on the line 3 3 of Fig. 2.

On the hollow spindle A of a screw-cutting lathe or other machine is secured a chuck B, carrying the usual dies for cutting the thread. The hollow spindle A is mounted to rotate in bearings C C', supported on a headstock D, attached to the bed E of the lathe, and on said bearings C C' are mounted to rotate loosely the driving-pulleys F F', respectively connected by straight and cross belts, respectively, with pulleys on an overhead counter-shaft, so that a forward rotary motion is given to the pulley F and a return motion is given to the pulley F', the latter also rotating at a high rate of speed to insure a quick reverse turning of the spindle.

The hubs of the pulleys F F' are provided with one or more teeth F<sup>2</sup> F<sup>3</sup>, respectively adapted to engage the inner ends of clutch-

levers G G', respectively fulcrumed on arms G<sup>2</sup> G<sup>3</sup>, respectively, both secured on the spindle A. The outer ends G<sup>4</sup> G<sup>5</sup> of the two clutch-levers are pressed on by springs G<sup>6</sup> G<sup>7</sup>, respectively, so that the inner ends of said levers are normally out of the path of the teeth F<sup>2</sup> F<sup>3</sup>, respectively. The outer ends of the clutch-levers G G' are adapted to be engaged by rounded-off ends H' H<sup>2</sup>, respectively, of a clutch-sleeve H, held to slide loosely on the spindle A, between the arms G<sup>2</sup> G<sup>3</sup>, as plainly indicated in the drawings. Now it will be seen that when the sleeve H is in the position shown in Figs. 1 and 2 then the end H' engages the outer end of the lever G, so that the inner end of the lever is swung downward into the path of the tooth F<sup>2</sup>, so that the rotary motion given to the pulley F is transmitted by the tooth F<sup>2</sup> to the lever G, and as the latter is fastened on the arm G<sup>2</sup>, secured to the spindle A, said spindle is revolved with the chuck B. When the sleeve H is moved to the left, then the end H' leaves the end G<sup>4</sup> of the lever G, and consequently the spring G<sup>6</sup> returns the lever to its normal position—that is, moves the inner end of the lever out of engagement with the tooth F<sup>2</sup>, so that the transmission of the power from the pulley F to the spindle A ceases.

When the sleeve H is shifted to the left, the end H<sup>2</sup> engages the end G<sup>5</sup> of the lever G' to impart a swinging motion to the latter and cause its inner end to move into the path of the tooth F<sup>3</sup>, whereby the rotary motion of the pulley F' is transmitted by the lever G' and tooth F<sup>3</sup> to the spindle A, but in a reverse direction to that previously given to the pulley F.

The sleeve H can be shifted either from the carriage I, supporting the work, or by the latter directly. In the former case I provide the following device: The sleeve H is formed with an annular groove engaged by the free end of a shifting-lever J, having its fulcrum-shaft J', journaled in suitable bearings, attached to the bed E of the lathe. On the shaft J' is secured a weighted arm J<sup>2</sup> and an upwardly-extending arm J<sup>3</sup>, through which passes loosely a rod K, rigidly attached to the carriage I. On the rod K are two stop-collars K' K<sup>2</sup>, respectively, adjustably held in the usual manner and adapted to engage the op-

posite sides of the arm  $J^3$  to impart a forward or backward swinging motion to the same, according to the movement of the carriage I. Now it will be seen that by this arrangement the carriage I, by the rod K and stop-collars  $K^1 K^2$ , imparts motion to the fork J, so that the latter shifts the sleeve H to the right or to the left, according to the length of feed given to the carriage I. The shifting of the sleeve H causes a turning of the spindle A first in one and then in the opposite direction, as above explained.

When it is desired to shift the sleeve H directly by the work, then the work engages the head  $L'$  of a screw L, screwing in a nut N, fitted to the hollow spindle A and connected by pins O with the sleeve H, said pins extending through elongated slots in the spindle A. (See Fig. 3.) Now it will be seen that while cutting the thread the work engages with the head  $L'$ , shifts the nut N to the left to move the sleeve H out of engagement with the lever G, and spring  $G^6$  and weight  $G^2$  force the sleeve H to the left, so as to engage lever  $G'$  automatically. Spring  $G^6$  is stronger and forces sleeve into engagement with  $G^7$ .

It will be seen that the device is very simple and durable in construction, is not liable to get out of order, and is entirely positive in its movement.

It is further understood that both devices are preferably put on a lathe for shifting the sleeve H in the manner above described.

Having thus fully described my invention, I claim as new and desire to secure by Letters Patent—

1. A reversing-gear of the class described, comprising a spindle, two driving-pulleys rotating in opposite directions and independent of the spindle, a clutch-sleeve held to slide on said spindle between the said pulleys, a fulcrumed shifting-lever engaging said clutch-sleeve and carrying a weighted arm, two clutches carried by the spindle and controlled by said sleeve, the clutches being adapted to engage said driving-pulleys, and means for moving said shifting-lever, substantially as shown and described.

2. A reversing-gear of the class described, comprising two clutch-arms secured on the spindle, spring-pressed levers fulcrumed on said clutch-arms, a sleeve held to slide on the spindle between said arms to engage either of

the said clutch-levers, a fulcrumed shifting-rod engaging the said sleeve, a weighted arm on the fulcrum-shaft of said lever, means for moving the said shifting-lever, and two driving-pulleys rotating independently of the spindle and in opposite directions, the said pulleys being adapted to engage the clutch-levers and carry the same around to rotate the spindle in the direction of the corresponding pulley, substantially as shown and described.

3. A reversing-gear of the class described, comprising a spindle, a clutch-sleeve held to slide on said spindle, two clutches carried by the spindle and controlled by said sleeve, the clutches being adapted to engage driving-pulleys rotating in opposite directions, a screw-rod adapted to be engaged by the work, and a nut connected with the said sleeve and in which screws the said screw-rod, substantially as shown and described.

4. A reversing-gear of the class described, comprising a hollow spindle, two driving-pulleys rotating in opposite directions and independent of the spindle and concentric thereto, a clutch-sleeve held to slide on said spindle between said pulleys, a shifting-lever engaging said clutch-sleeve, two clutches carried by the spindle and controlled by the sleeve the clutches being adapted to engage said driving-pulleys, and a rod extending within the hollow spindle and connected with the said sleeve, substantially as shown and described.

5. A reversing-gear of the class described, comprising two clutch-arms secured on the spindle, spring-pressed levers fulcrumed on said clutch-arms, a sleeve held to slide on the spindle between said arms, to engage either of the said clutch-levers, two driving-pulleys rotating independently of the spindle and in opposite directions, the said pulleys being adapted to engage said clutch-levers and carry the same around to rotate the spindle in the direction of the corresponding pulley, a screw-rod extending within the hollow spindle, and a nut in which screws said screw-rod, and connected with said sleeve, substantially as shown and described.

CHARLES WAGNER.

Witnesses:

THEO. G. HOSTER,  
JNO. M. RITTER.